

Big Foot Standard Frames

Light Duty Frames



Non-penetrative support frames for air conditioning multi frames, mini-splits, VRFs and small AHUs

The LD standard product range consists of three standard modular frames, available in 1m, 2m and 3m arrangements. This ensures minimal cross-member deflection whilst maintaining structural stability; as opposed to weaker alternatives often constructed from poor quality pre galvanised strut. Our highly competent engineers and designers have developed the product range through our rigorous product development cycle, including validation through testing.

In order to facilitate the process of identifying the required frame for the specified air conditioning manufacturers Splits or VRF/VRV units (or indeed a combination of both) Big Foot Systems have created 'Frame Selectors'.

For further details contact the Big Foot Systems Technical Office on +44 (0)1323 844 355.

compatible with all leading VRV/VRF manufacturers products

Standard Frames

- Adjustable leg assemblies
- Feet supplied with rubber mats
- 40 x 40 box section frame
- Supplied boxed with clamp kits

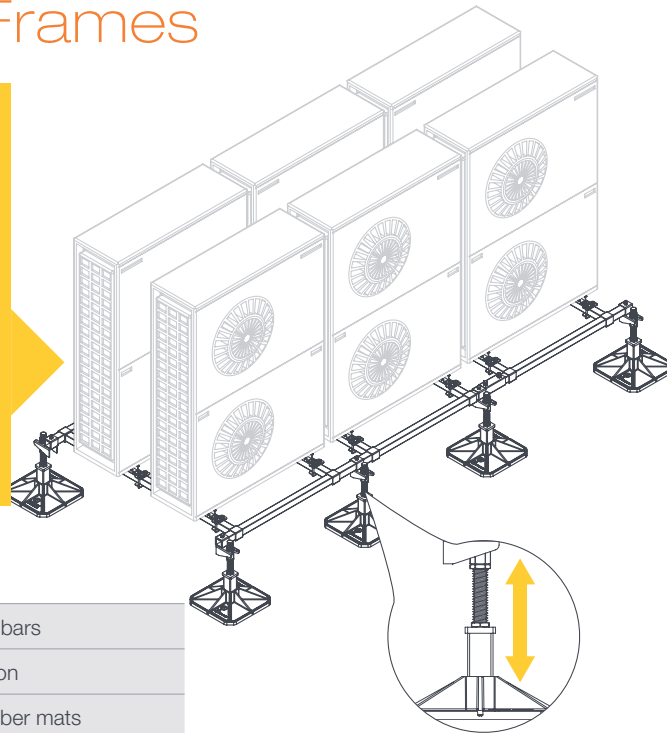

KIT INCLUDES

- 40mm x 40mm box section end bars
- 1.2m Cross bars – 40 x 40 section
- 305mm Leg assemblies with rubber mats
- Condenser Clamp kits
- Assembly instructions

PRODUCT INFORMATION

Model	1m Modular Frame	2m Modular Frame	3m Modular Frame
Part no.	B6075	B6077	B6078
Height (mm)	290-400	290-400	290-400
Width (mm)	1200	1200	1200
Length (mm)	1000	2000	3000
Weight (kg)	40	69	93
Max. loading (kg)	480	720	960

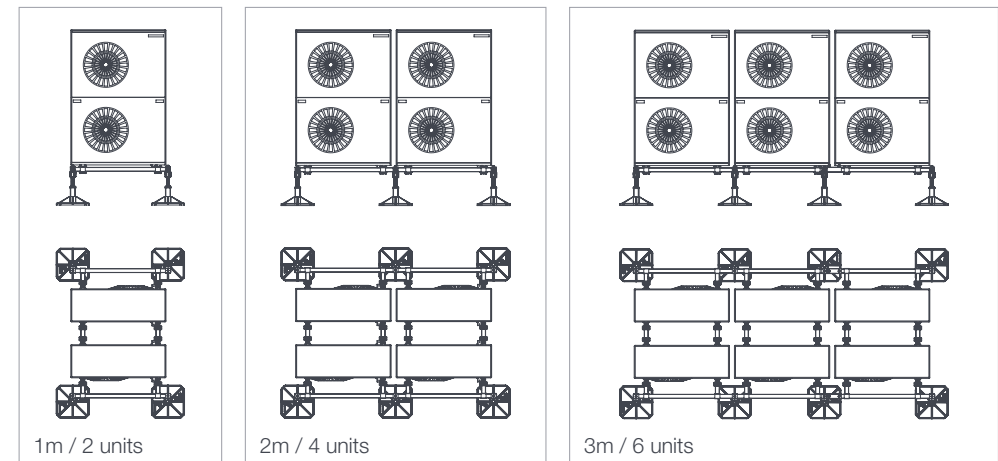

1m / 2 units

2m / 4 units

3m / 6 units