

R E P O R T**IB-10-8-023****about the experimental testing of enclosed-break devices****(Translation)****1 Order**

Danfoss A/S in 6430 Nordborg (DENMARK) engaged with e-mail of 07 April 2010 the IBExU Institut für Sicherheitstechnik GmbH with the experimental testing of the Relays Omron G2RL-1A-E and Tyco OJ-SS-112LMH2-WG in explosive atmosphere regarding the proof of type of protection enclosed-break devices according to IEC/EN 60079-15:2005, paragraph 33.4.

2 Test item

Relays

- Manufacturer:	Omron	Tyco
- Type:	G2RL-1A-E	OJ-SS-112LMH2-WG
- Coil voltage:	24 V DC	12 V DC
- Contact voltage:	250 V	250 V
- Current:	16 A	8 A
- cos phi:	0.6	0.6
- Service temperature range:	-25 °C up to + 70 °C	-25 °C up to + 70 °C

3 Test documents

- Order with E-Mail of 07 April 2010
- Order confirmation with letter Hi/Leh 2122/10 of 08 April 2010
- EN 60079-15:2005 (complies with IEC 60079-15:2005, ed. 3)
- 4 pieces of Relays Omron type G2RL-1A-E (EXel 134/10)
- 4 pieces of Relays Tyco type OJ-SS-112LMH2-WG (EXel 133/10)

The test items were delivered to IBExU on 31 March 2010.

4 Test execution**4.1 Objectives**

It was the task to examine experimentally the ignition safety (the non-ignition of an explosive atmosphere) of the Relays for gases and vapors of the Group IIA with the parameters specified under chapter 2. Basis of the test are the requirements in IEC/EN 60079-15:2005, Paragraph 33.4 for enclosed-break devices.

In the context of these examinations there was not the task to check the constructive requirements for apparatus in type of protection "n" (apparatus for zone 2) for the compliance with IEC/EN 60079-15.

4.2 Description of the test items

The Relays mentioned in 2 were used in cooling equipment of the company Danfoss.

- Relay Omron G2RL-1A-E



The enclosure of the Relay type G2RL-1A-E consists of a black plastic cover and a white plastic base. The bottom side of the enclosure is closed with a black casting compound. A little hole with a diameter of < 0.5 mm is in the housing top side. The relay coil and a contact pair are assembled on the white plastic base in the housing inside. In this version the relay functions as closing contact. On the underside of the housing the switch contacts and the coil contacts are led to the outside as solder legs.

The free internal volume of the switch chamber is less than 20 cm^3 ($\sim 0.5 \text{ cm}^3$).

- Relay Tyco OJ-SS-112LMH2-WG



The enclosure of the Relay type OJ-SS-112LMH2-WG consists of a white plastic cover and a white plastic base. The bottom side of the enclosure is closed with a black casting compound. In one corner of the top side is a small hole with a diameter of < 0.5 mm. The relay coil and a contact pair are assembled on the plastic base in the housing inside. In this version the relay functions as closing contact. On the underside of the housing the switch contacts and the coil contacts are led to the outside as solder legs. The free internal volume of the switch chamber is less than 20 cm^3 ($\sim 0.4 \text{ cm}^3$).

The enclosures of the test samples were equipped with a hose connection via a borehole. It serves to purge the switch chamber with the test gas and also for the uptake of the thermocouple. A second borehole with hose connection served for the discharge of the test gas during the purging.

4.3 Requirements in IEC/EN 60079-15:2005

Enclosed-break devices are devices, which incorporate electrical contacts that are made and broken. These devices will withstand an internal explosion of the flammable gas or vapor which may enter it without suffering damage and without communicating the internal explosion to the external flammable gas or vapor.

Before the tests any removable seals have to be removed. Any remaining non-metallic parts will have been subjected to the conditioning test described in paragraph 33.3.2. These parts have to be stored continuously for four weeks in an ambience of 90 % relative humidity and at a temperature of 10 K above the maximum temperature in rated service.

In case of a maximum service temperature above 85 °C the period of four weeks specified above will be replaced by a period of two weeks at 95 °C and 90 % relative humidity followed by a period of two weeks at a temperature of 10 K above the maximum temperature in rated service. After that, a storage for 24 hrs at a temperature of 5 K below the minimal ambient temperature shall be carried out.

Then the test of the enclosed-break devices according to paragraph 33.4.3 will be carried out. The explosive gas atmosphere fixed for the Group IIA, IIB or IIC has to be ignited inside the device by the operation of the enclosed contacts when connected to the maximum rated source of energy, power and load in terms of voltage, current, frequency and power factor.

A make and break test shall be repeated 10 times with a fresh gas mixture for each test. After the test, the device shall show no visible signs of damage; no external ignition shall occur and there shall be no failure to clear the arc when the switch contacts are opened.

4.4 Description of the test equipment

The test equipment is schematically shown in annex 1 of this report. It consists of the following equipment and means of work:

Explosion chamber

The explosion chamber essentially consists of a cylindrical container (Piacryl) with a bursting foil mounted on the top. The volume amounts 18 dm³.

In the base plate and on the cylinder are introduced and sealed the instrument leads and the supply lines.

Conditioning of the test gas mixture

The explosive gas atmosphere required for the Group IIA (6.5 % ± 0.5 % Ethylene, 93.5 % ± 0.5 % air) was processed in the explosion chamber by volumetric gas conditioning. Dosage equipment with Digital Mass Flow Controllers served for this.

The homogeneous mixture conditioning was ensured by flushing the explosion chamber and the test item with the explosive gas/air mixture. The burning gas quota (Ethylene) in the explosion chamber was checked in addition for the maintenance of the permissible tolerance with a gas interferometer according to Rayleigh-Haber-Löwe (PM 0301).

Measuring device for electrical parameters

The predefined electrical load of the switching contacts was made by switching on ohmic resistors and inductances in the AC circuit.

With a Wide Band Power Analyzer D 6100 (manufacturer: Norma, PM 0010) the required parameters current, voltage and power factor were measured during the examining operation and registered with an 8-channel recorder type LR 8100 (manufacturer: YOKOGAWA, PM 0034).

The ignition in the test item was perceived acoustically and recorded by the temperature rise by means of a thermocouple. For that, a thermocouple was introduced into the tube connection on the test item after the mixture conditioning. The temperature course was recorded with the recorder.

Test of thermal endurance

The test of thermal endurance occurs in conditioning and refrigeration cabinets which are also used for the thermal endurance tests according to EN 60079-0.

All used measuring instruments are included in the Quality Management System of IBExU certified according to ISO 9001. They are checked in regular intervals.

4.5 Test procedure and results

4.5.1 *Test of thermal endurance*

The test of thermal endurance was carried out according to IEC/EN 60079-15, 33.3.2. The test samples were stored for 4 weeks at 80 °C heat and 90 % rel. humidity, followed by 24 hrs at -30 °C cold.

No damages at the test samples were noticed at the following visual inspection.

4.5.2 *Pre-test*

Before the ignition tests specified in IEC/EN 60079-15 were carried out it had to be made sure that the appearing switching spark in the case can be considered as an effective ignition source for the test gas.

To this, pre-tests were carried out at one test sample per type, whose enclosure was opened. At the respective test parameters 250 V, 16 A respectively 8 A and $\cos \varphi 0.6$ the ignition of the explosive gas mixture caused by the break spark could be proved (see Annex 2.1).

4.5.3 Type test

The tests were carried out on 14 and 18 May 2010. In accordance with IEC/EN 60079-15, 33.4.3.2 eleven tests have to be carried out with a sample, which has the most adverse dimensions permitted by the construction drawings. There are no statements regarding the gaps of the test samples. To make sure the test results, at least three test samples per type were included into the test program. The Relay type Tyco OJ-SS-112LMH2-WG could be tested only with three test samples, because the coil of one test sample was damaged at the producing of the test hole.

The respective test sample (originally closed) to be tested was put into the explosion chamber. The specified explosive gas atmosphere required for the Group IIA was processed in the explosion chamber and in the enclosure of the test item.

The contacts of the Relays were operated with the preset test parameters. The ignition of the explosive gas atmosphere inside the test item occurred by the break spark.

The test results are summarised in the table. For some tests the test parameters are recorded in the annexes 2.2 up to 2.8.

Type	Test sample No.	Tests	Electrical parameters			Ignition of the explosive atmosphere	
			U [V]	I [A]	cos φ	Inside the test item	outside
Relay Omron G2RL-1A-E	1	11	250	16	0.6	yes	no
	2	11	250	16	0.6	yes	no
	3	11	250	16	0.6	yes	no
	4	11	250	16	0.6	yes	no
Relay Tyco OJ-SS-112LMH2-WG	1	11	250	8	0.6	yes	no
	2	11	250	8	0.6	yes	no
	3	11	250	8	0.6	yes	no

At none of the ignition tests the explosion triggered in the enclosure of the test sample was transferred to the outer explosive atmosphere. No damages were noticed at the enclosure.

5 Summary

It was noticed with the examinations that the Relays type Omron G2RL-1A-E and type Tyco OJ-SS-112LMH2-WG at the conditions mentioned under 2 have the ignition safety (the non-ignition of an explosive atmosphere) fixed in IEC/EN 60079-15:2005 according to type of protection enclosed-break device for gases and vapors of the Group IIA. The explosions triggered inside the switching chamber by the break spark did not ignite the explosive mixture surrounding the device.

The assessment of the constructive design of the Relays regarding the compliance with the requirements of IEC/EN 60079-15 for apparatus of the type of protection "n" (apparatus for zone 2) was not object of these examinations.

The test result refers exclusively to the Relays specified under chapter 2.

Annexes

Annex 1	Schematic setup of the test equipment
Annex 2	Representation of the test parameters (8 Sheet)

Annex 1: Schematic setup of the test equipment

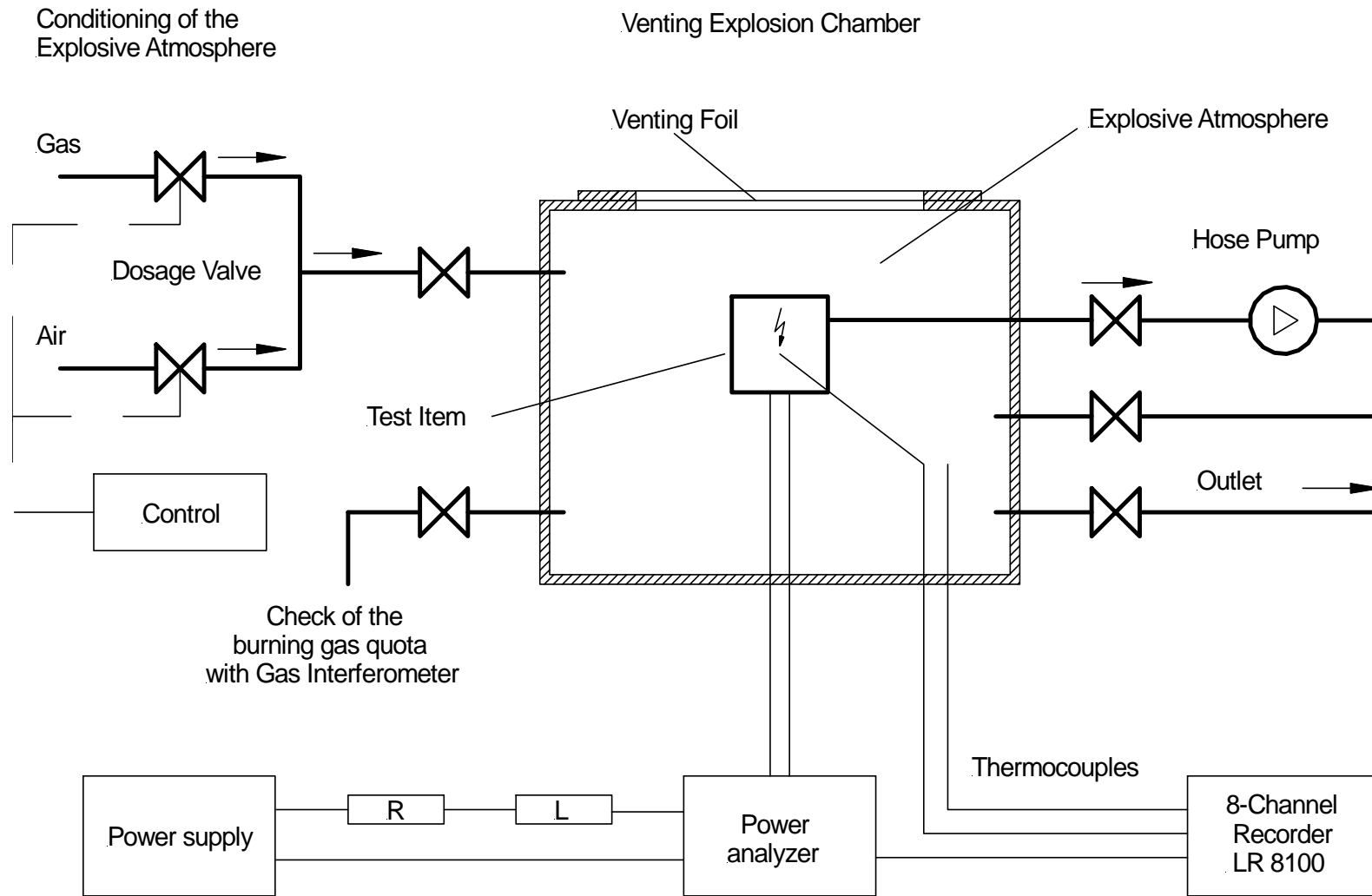

**Test parameters Pre-test
(Beispiel Relay Omron G2RL-1A-E)**

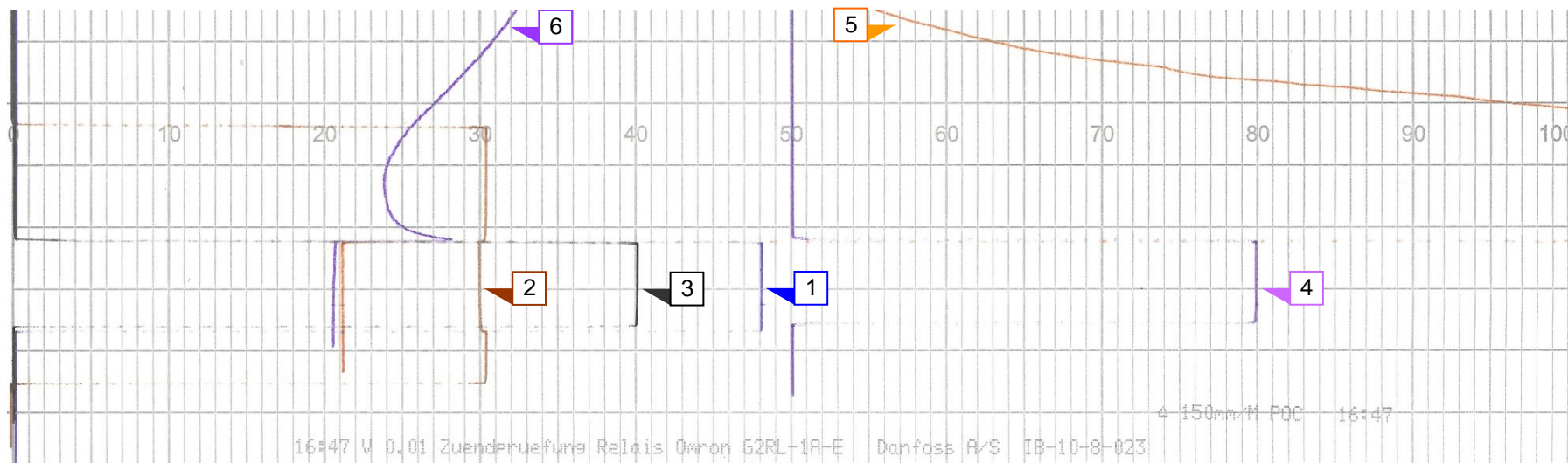

Recorder speed: 4 s/scale

Remarks:

- 1 - Coil voltage
- 2 - Voltage
- 3 - Current
- 4 - Power factor
- 5 - Temperature test chamber
- 6 - Temperature test item

- Range 0 ... 50 V
- Range 0 ... 833.3 V
- Range 0 ... 40 A
- Range 1_{cap.} ... 0 ... 1_{ind.}
- Range 0 ... 100 °C
- Range 0 ... 100 °C

Test parameters Relay Omron G2RL-1A-E - Test No. 1.08

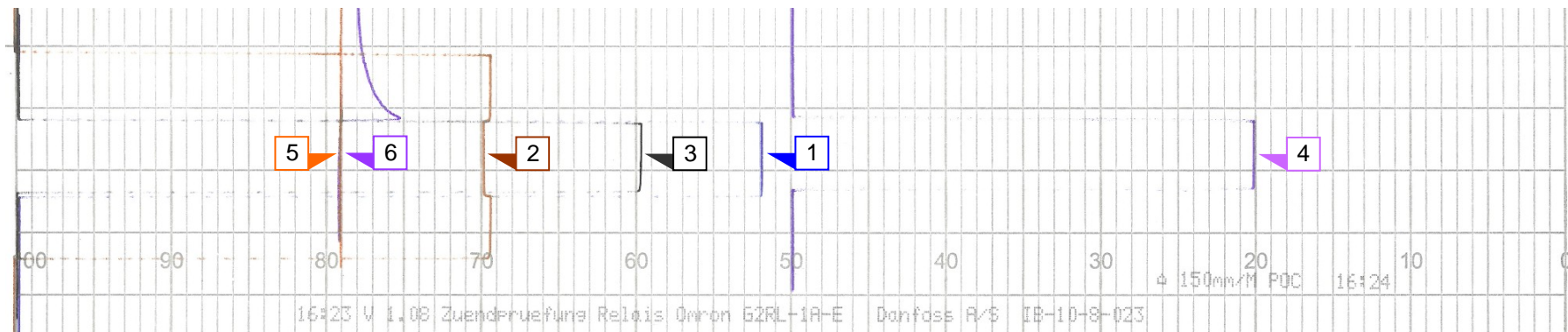

Recorder speed: 4 s/scale

Remarks:

- 1 - Coil voltage
- 2 - Voltage
- 3 - Current
- 4 - Power factor
- 5 - Temperature test chamber
- 6 - Temperature test item

- Range 0 ... 50 V
- Range 0 ... 833.3 V
- Range 0 ... 40 A
- Range 1_{cap.} ... 0 ... 1_{ind.}
- Range 0 ... 100 °C
- Range 0 ... 100 °C

Test parameters Relay Omron G2RL-1A-E - Test No. 2.06

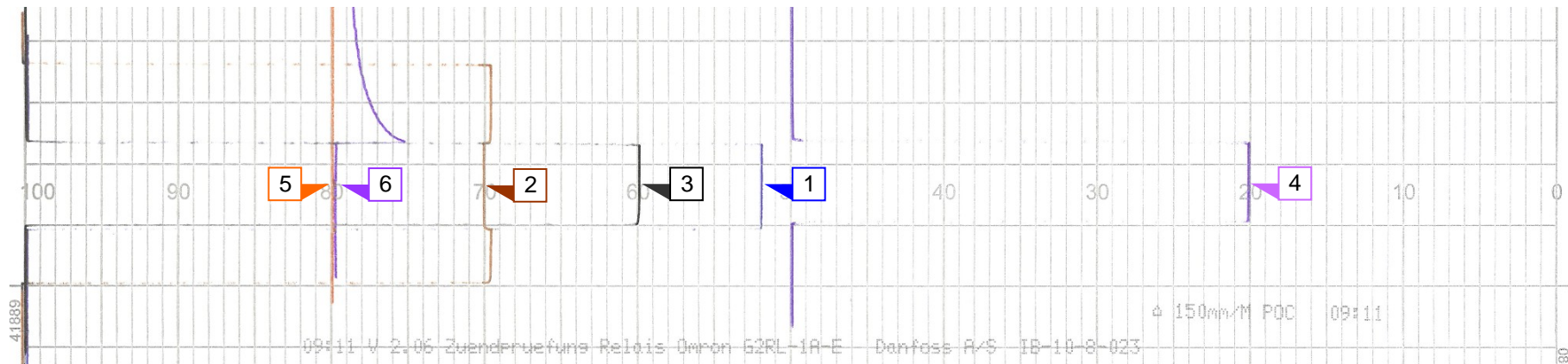

Recorder speed: 4 s/scale

Remarks:

- 1 - Coil voltage
- 2 - Voltage
- 3 - Current
- 4 - Power factor
- 5 - Temperature test chamber
- 6 - Temperature test item

- Range 0 ... 50 V
- Range 0 ... 833.3 V
- Range 0 ... 40 A
- Range 1_{cap.} ... 0 ... 1_{ind.}
- Range 0 ... 100 °C
- Range 0 ... 100 °C

Test parameters Relay Omron G2RL-1A-E - Test No. 3.01

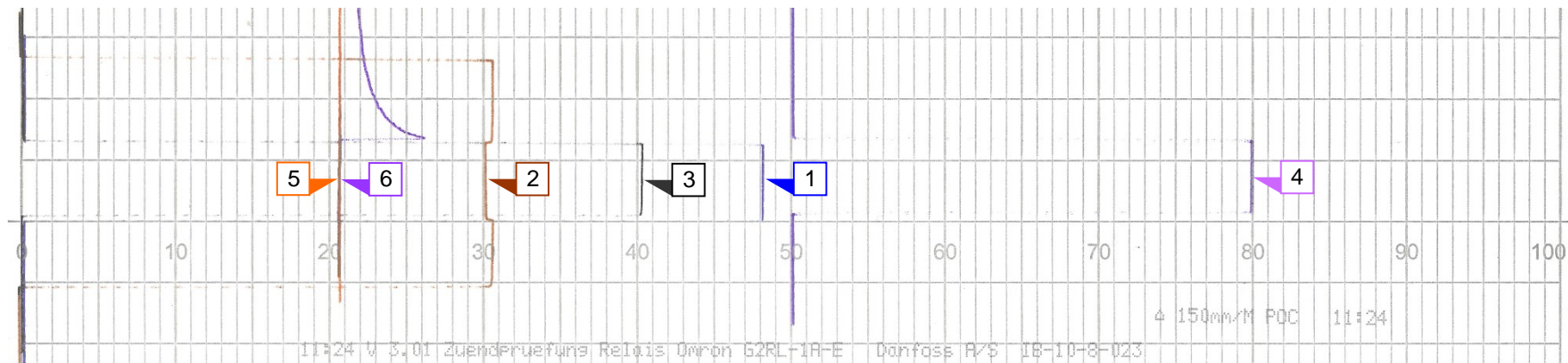

Recorder speed: 4 s/scale

Remarks:

- 1 - Coil voltage
- 2 - Voltage
- 3 - Current
- 4 - Power factor
- 5 - Temperature test chamber
- 6 - Temperature test item

- Range 0 ... 50 V
- Range 0 ... 833.3 V
- Range 0 ... 40 A
- Range 1_{cap.} ... 0 ... 1_{ind.}
- Range 0 ... 100 °C
- Range 0 ... 100 °C

Test parameters Relay Omron G2RL-1A-E - Test No. 4.05

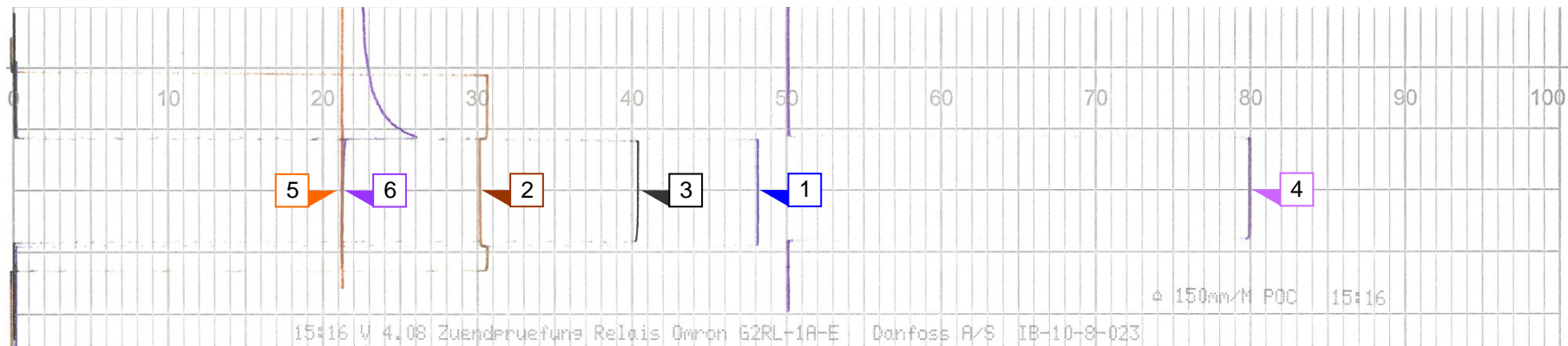

Recorder speed: 4 s/scale

Remarks:

- 1 - Coil voltage
- 2 - Voltage
- 3 - Current
- 4 - Power factor
- 5 - Temperature test chamber
- 6 - Temperature test item

- Range 0 ... 50 V
- Range 0 ... 833.3 V
- Range 0 ... 40 A
- Range 1_{cap.} ... 0 ... 1_{ind.}
- Range 0 ... 100 °C
- Range 0 ... 100 °C

Test parameters Relay Tyco OJ-SS-112LMH2-WG Test No. 1.08

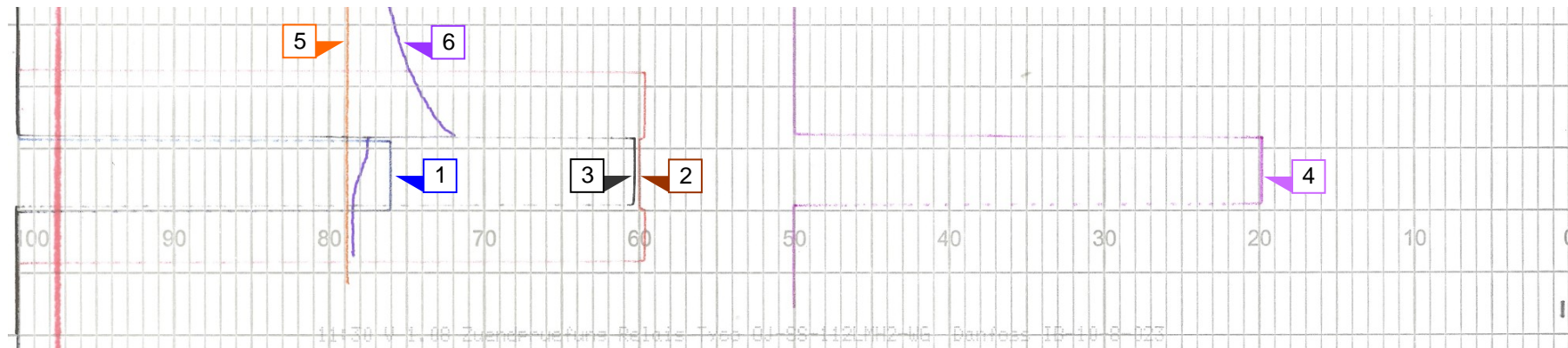

Recorder speed: 4 s/scale

Remarks:

- 1 - Coil voltage
- 2 - Voltage
- 3 - Current
- 4 - Power factor
- 5 - Temperature test chamber
- 6 - Temperature test item

- Range 0 ... 50 V
- Range 0 ... 625 V
- Range 0 ... 20 A
- Range 1_{cap.} ... 0 ... 1_{ind.}
- Range 0 ... 100 °C
- Range 0 ... 100 °C

Test parameters Relay Tyco OJ-SS-112LMH2-WG - Test No. 2.10

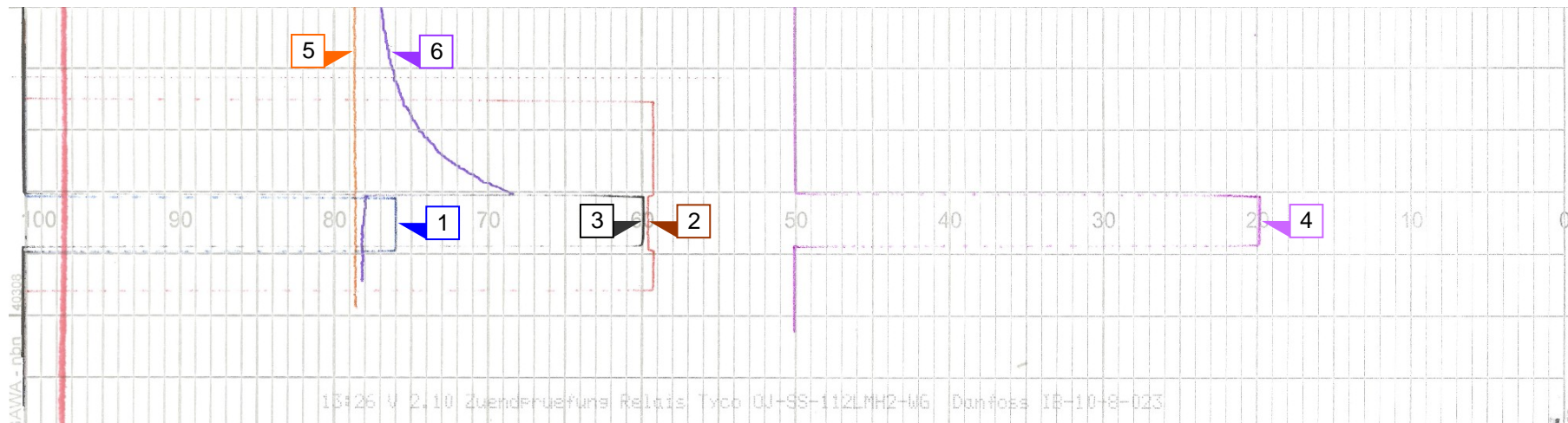

Recorder speed: 4 s/scale

Remarks:

- 1 - Coil voltage
- 2 - Voltage
- 3 - Current
- 4 - Power factor
- 5 - Temperature test chamber
- 6 - Temperature test item

- Range 0 ... 50 V
- Range 0 ... 625 V
- Range 0 ... 20 A
- Range 1_{cap.} ... 0 ... 1_{ind.}
- Range 0 ... 100 °C
- Range 0 ... 100 °C

Test parameters Relay Tyco OJ-SS-112LMH2-WG - Test No. 3.10

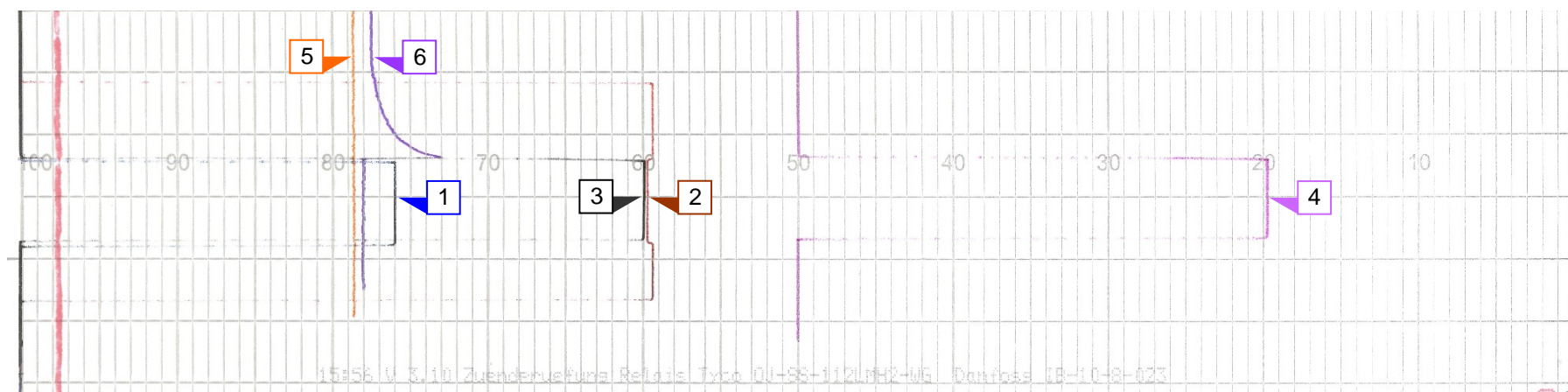

Recorder speed: 4 s/scale

Remarks:

- 1 - Coil voltage
- 2 - Voltage
- 3 - Current
- 4 - Power factor
- 5 - Temperature test chamber
- 6 - Temperature test item

- Range 0 ... 50 V
- Range 0 ... 625 V
- Range 0 ... 20 A
- Range 1_{cap.} ... 0 ... 1_{ind.}
- Range 0 ... 100 °C
- Range 0 ... 100 °C